

CARVE FIRE TABLE

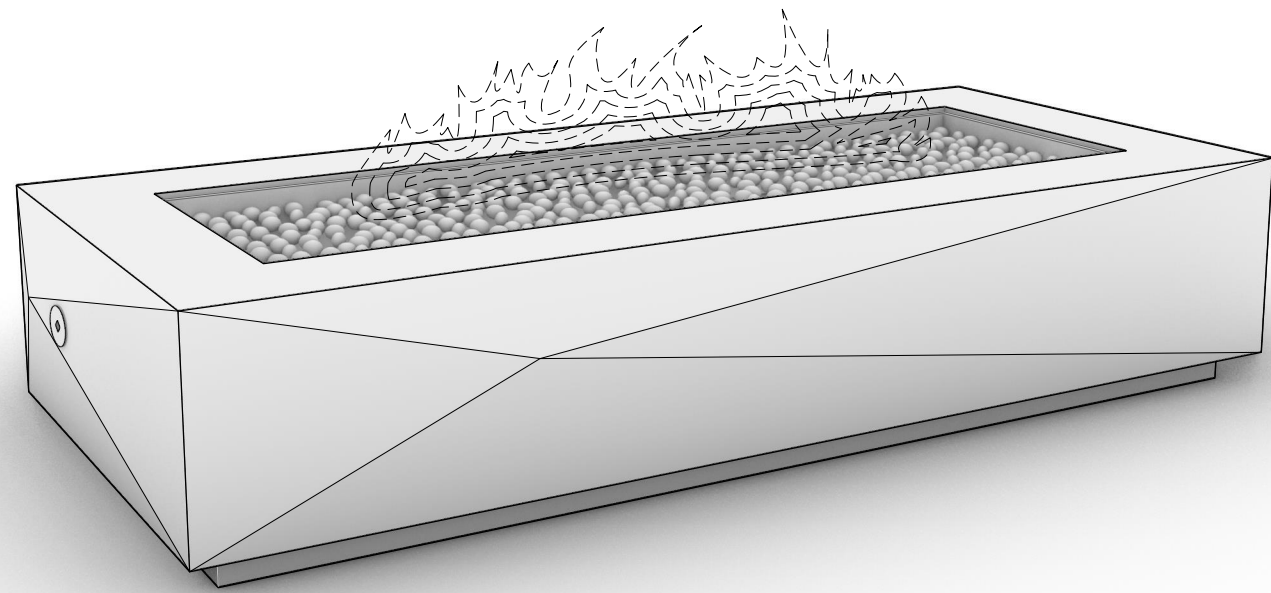

CV.1.1 PERSPECTIVE VIEW
SCALE: NA

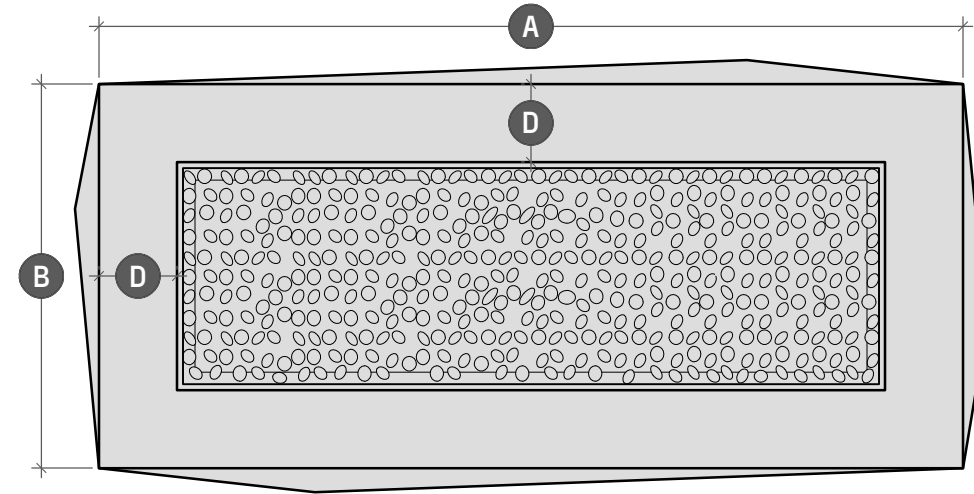

CV.1.2 PLAN VIEW
SCALE: 1" = 1' - 3"

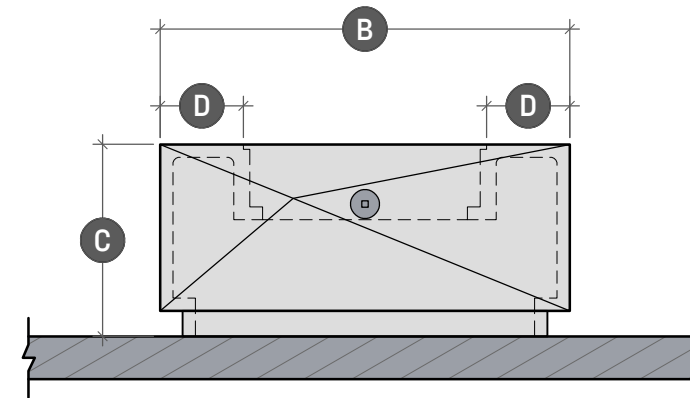

CV.1.3 SIDE ELEVATION
SCALE: 1" = 1' - 3"

	CARVE 52	CARVE 62	CARVE 72	CARVE 82
Length	A - 52"	A - 62"	A - 72"	A - 82"
Width	B - 32"	B - 32"	B - 32"	B - 32"
Height	C - 15"	C - 15"	C - 15"	C - 15"
Surface	D - 6 1/2"	D - 6 1/2"	D - 6 1/2"	D - 6 1/2"

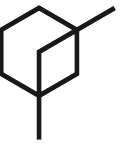

LUMACAST

3261 National Ave
San Diego, CA 92113
t: +1 888 710 1026
www.lumacast.com

PROJECT INFORMATION

PROJECT:
LUMACAST FIRE TABLE
CARVE

DESIGNER:
LUMACAST

DRAWING INFORMATION

DRAWING PACKAGE:
2D SHOP DRAWINGS
SHEET CONTENTS:
COVER SHEET

MORE INFORMATION



SCAN TO LEARN MORE

AUTHOR AUTHOR
EGI 09/23

CV.1

SHEET NO

MINIMUM CLEARANCES TO COMBUSTIBLES

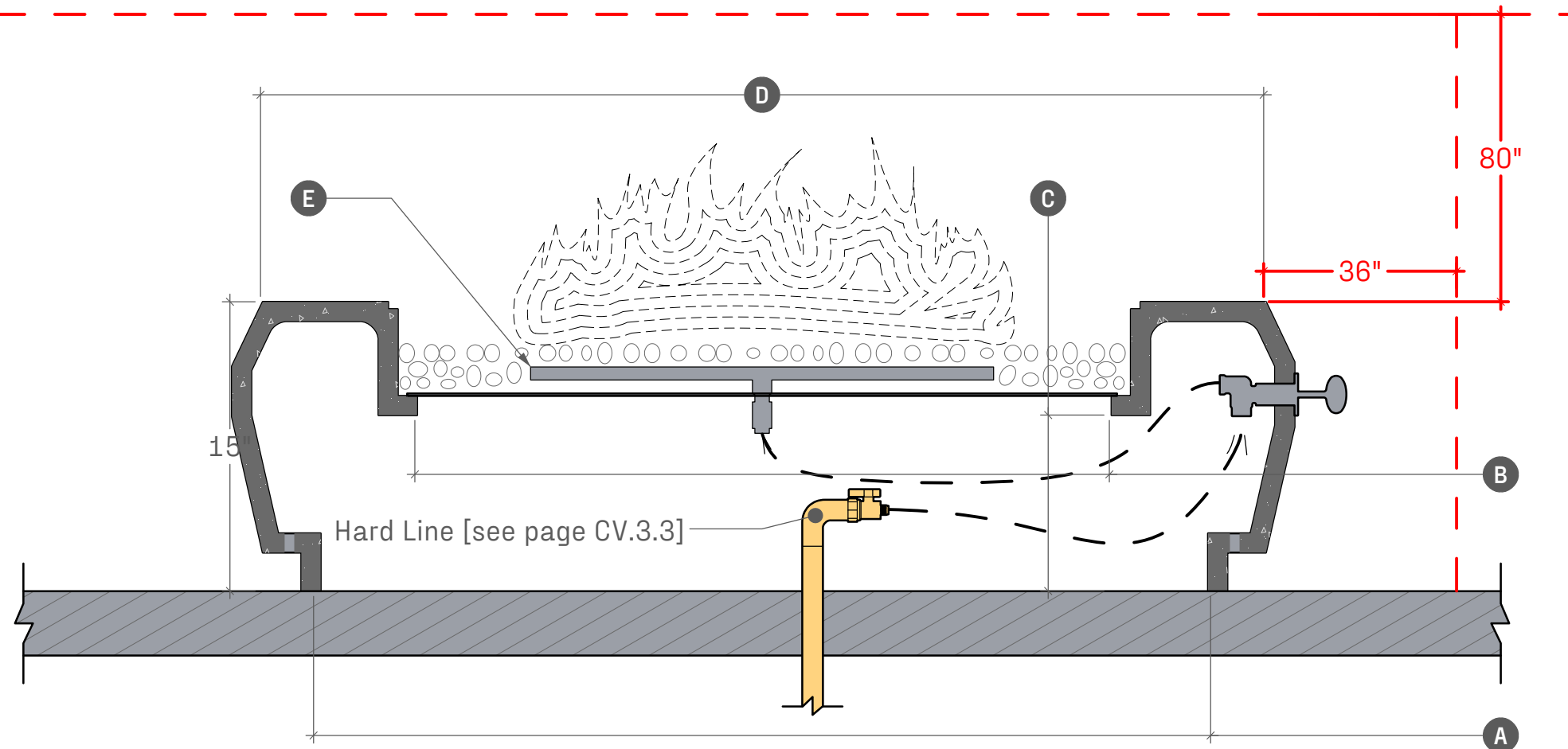

CV.2.1 SECTION DETAIL
SCALE: 1" = 0' - 8"

	CARVE 52	CARVE 62	CARVE 72	CARVE 82
Opening at Base	A - 46" x 26"	A - 56" x 26"	A - 66" x 26"	A - 76" x 26"
Burner Pan Access	B - 36" x 16"	B - 46" x 16"	B - 56" x 16"	B - 66" x 16"
Burner Pan Height	C - 9"	C - 9"	C - 9"	C - 9"
Length	D - 52" x 32"	D - 62" x 32"	D - 72" x 32"	D - 82" x 32"
Burner Options	E - - -	E - - -	E - - -	E - - -
Stainless Steel Burner	75,000 BTU	100,000 BTU	125,000 BTU	150,000 BTU
Warming Trands Burner	110,000 BTU*	170,000 BTU*	210,000 BTU*	270,000 BTU
Crated Dimensions	55"x35"x23"	65"x35"x23"	75"x35"x23"	85"x35"x23"
Shipping Weight	500 LBS	550 LBS	600 LBS	650 LBS
Shell Weight	250 LBS	300 LBS	350 LBS	400 LBS

WARNINGS

FOR OUTDOOR USE ONLY

POTENTIAL CARBON MONOXIDE HAZARD

Do not store or use flammable liquids in the vicinity of this product

To be installed by licensed plumber or contractor

TYPICAL CLEARANCES

36" of clearance from the side elevations of the fire table

80" of clearance from the top surface of the fire table

NATURAL GAS SUPPLY

Ensure that the service supplying the fire feature is fitted with a positioned shut off valve that is easily accessible

SUPPLY PRESSURE

Minimum - 3.5" WC

Normal - 7.0" WC

Maximum - 14.0" WC (1/2psi)

- - -

Check with local inspector if any further specifications are required for permitted installations



LUMACAST

3261 National Ave
San Diego, CA 92113
t: +1 888 710 1026
www.lumacast.com

PROJECT INFORMATION

PROJECT:
LUMACAST FIRE TABLE
CARVE

DESIGNER:
LUMACAST

DRAWING INFORMATION

DRAWING PACKAGE:
2D SHOP DRAWINGS
SHEET CONTENTS:
SPECIFICATIONS

MORE INFORMATION



SCAN TO LEARN MORE

AUTHOR AUTHOR
EGI 09/23

CV.2

SHEET NO

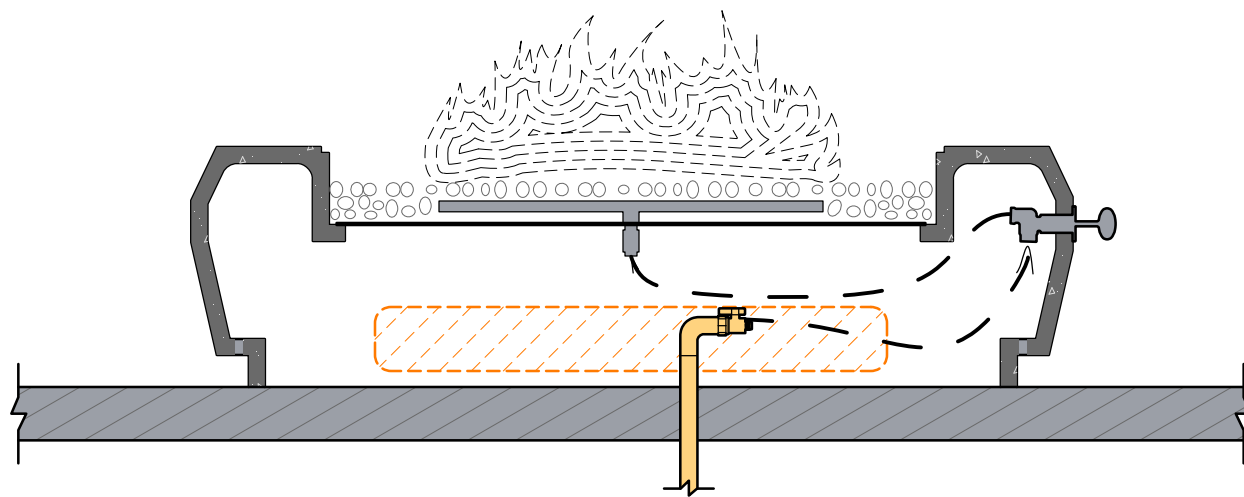

CV.3.1 SIDE SECTION
SCALE: 1" = 1' - 0"

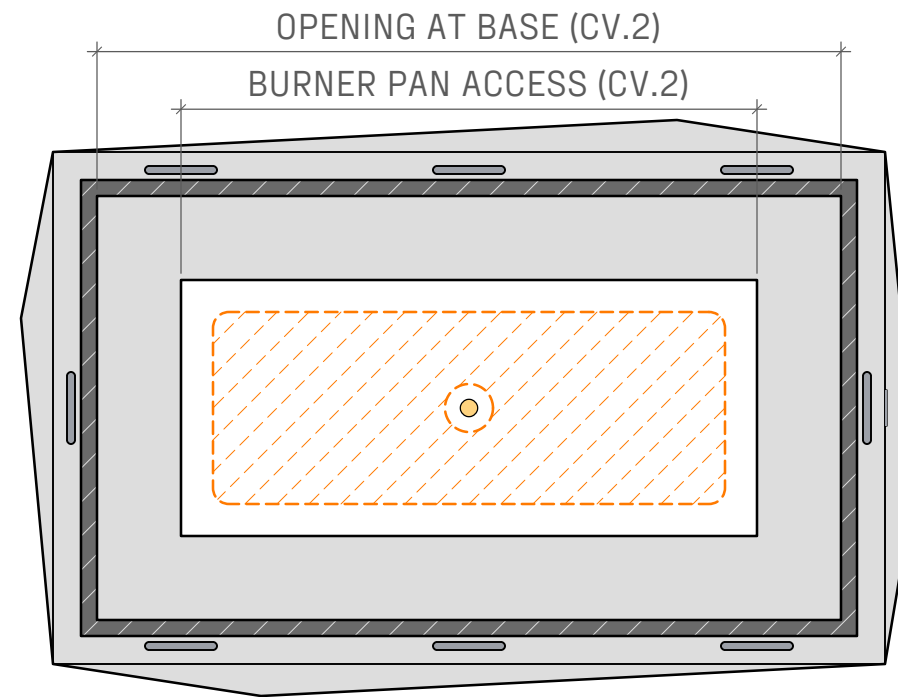

CV.3.2 PLAN VIEW
SCALE: 1" = 1' - 0"

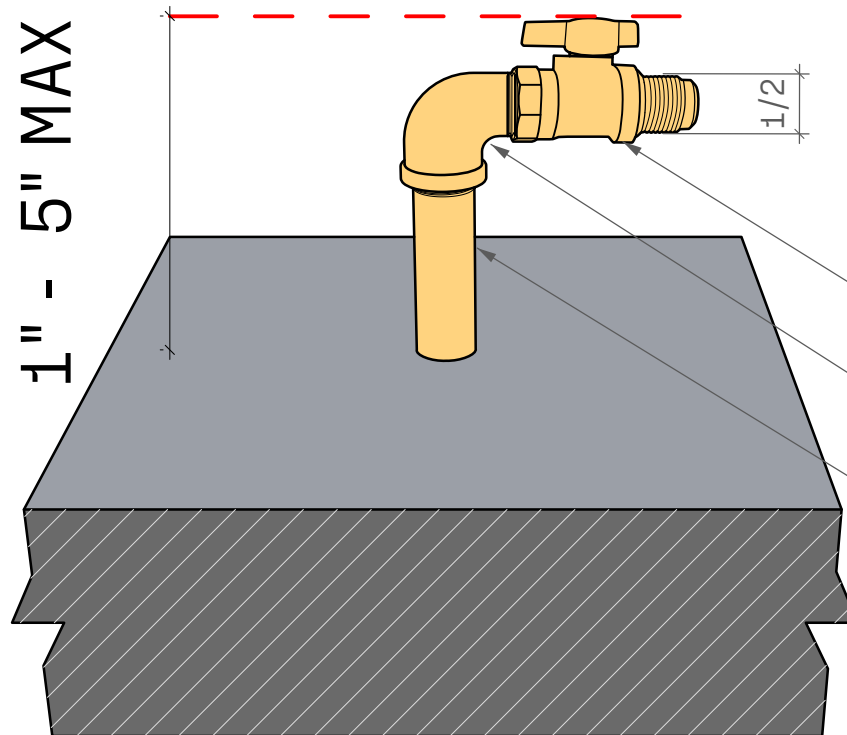

CV.3.3 PERSPECTIVE
SCALE: n/a

- BRASS FNPT X FLARE GAS BALL VALVE: 1/2"
- STREET ELBOW
- GALVANIZED NIPPLE 3/4" - 1" DEPENDING ON BTU SEE PLUMBER

PLUMBING HARD LINE

For successful installation, hardline stub up should be capped off between 1" and 5" off finished floor.

Lumacast White Glove Delivery and Installation can only be done on IPS Piping



LUMACAST

3261 National Ave
San Diego, CA 92113
t: +1 888 710 1026
www.lumacast.com

PROJECT INFORMATION

PROJECT:
LUMACAST FIRE TABLE
CARVE

DESIGNER:
LUMACAST

DRAWING INFORMATION

DRAWING PACKAGE:
2D SHOP DRAWINGS
SHEET CONTENTS:
HARDLINE DIAGRAM

MORE INFORMATION



SCAN TO LEARN MORE

AUTHOR	AUTHOR
EGI	09/23

CV.3

SHEET NO