

AURA squared FIRE TABLE

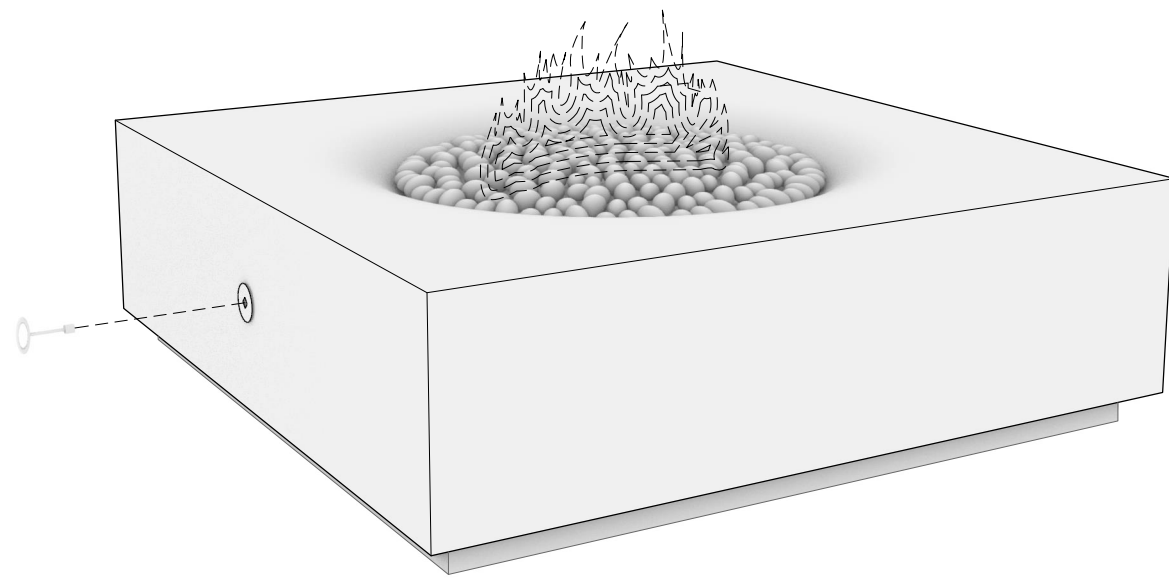

AU2.1.1 PERSPECTIVE VIEW
SCALE: NA

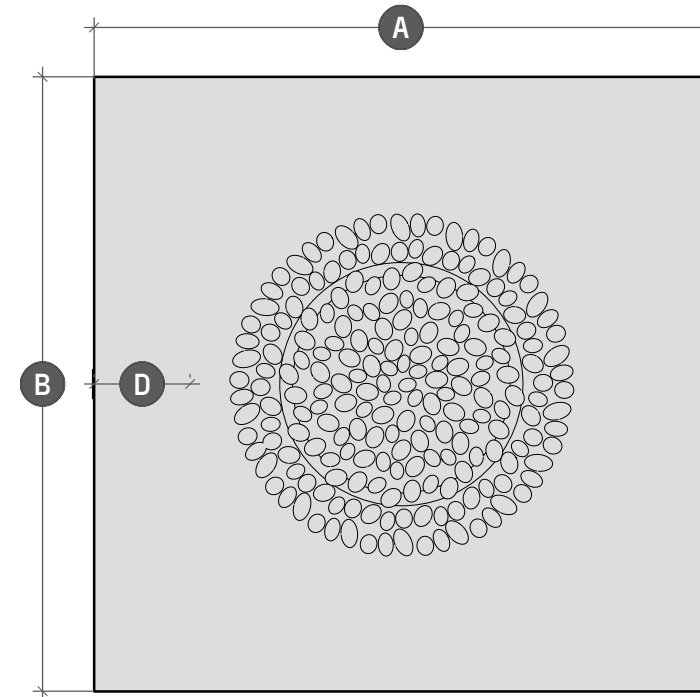

AU2.1.2 PLAN VIEW
SCALE: 1" = 1' - 3"

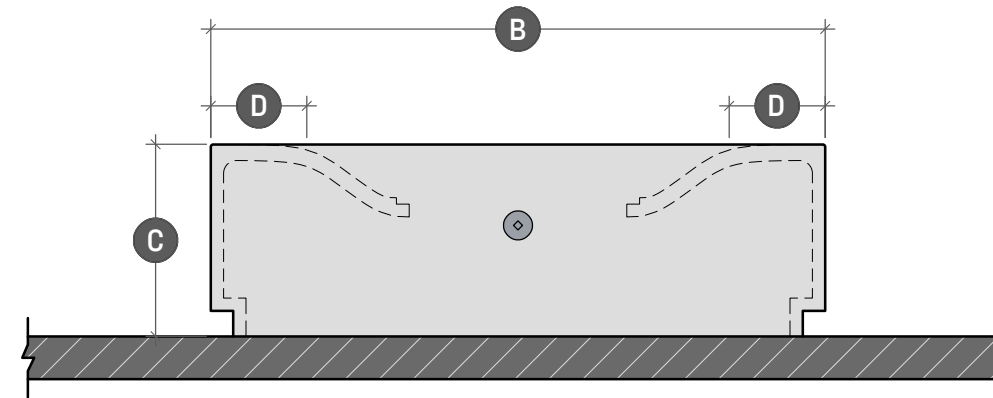

AU2.1.3 SIDE ELEVATION
SCALE: 1" = 1' - 3"

	AURA squared 36	AURA squared 42	AURA squared 48	AURA squared 52
Length	A - 36"	A - 42"	A - 48"	A - 52"
Width	B - 36"	B - 42"	B - 48"	B - 52"
Height	C - 13 15"	C - 13 15"	C - 15"	C - 15"
Surface	D - 4"	D - 4 1/4"	D - 4 1/2"	D - 4 3/4"

	*AVAILABLE IN STANDARD OR low
	Standard height is 15" Low height is 13"

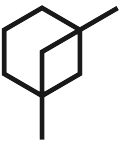

LUMACAST

3261 National Ave
San Diego, CA 92113
t: +1 888 710 1026
www.lumacast.com

PROJECT INFORMATION

PROJECT:
LUMACAST FIRE TABLE
AURA squared

DESIGNER:
LUMACAST

DRAWING INFORMATION

DRAWING PACKAGE:
2D SHOP DRAWINGS
SHEET CONTENTS:
COVER SHEET

MORE INFORMATION



SCAN TO LEARN MORE

AUTHOR AUTHOR
EGI 10/23

AU2

.1

SHEET NO

MINIMUM CLEARANCES TO COMBUSTIBLES

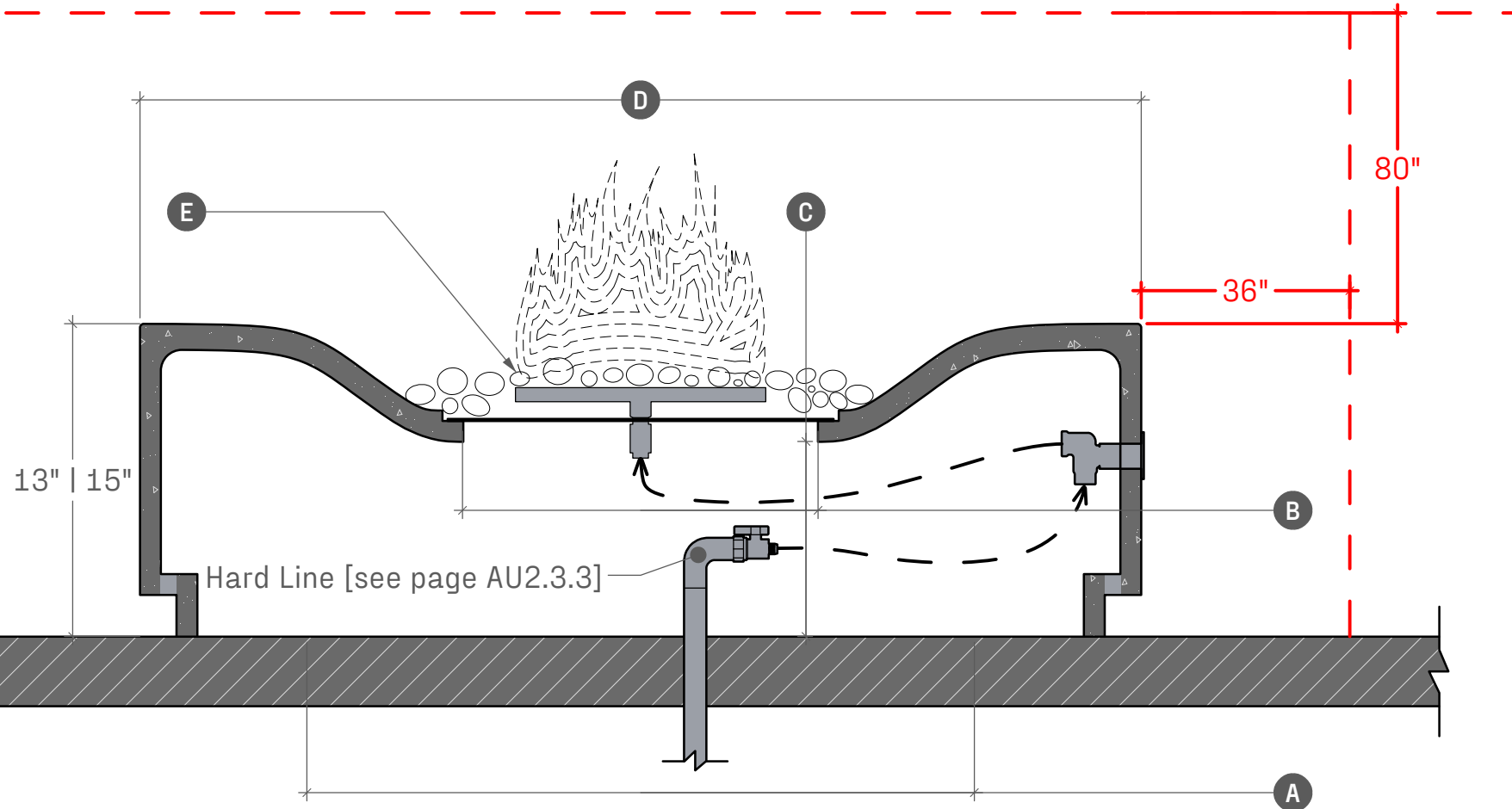

AU2.2.1 SECTION DETAIL
SCALE: 1" = 0' - 8"

	AURA squared 36*	AURA squared 42*	AURA squared 48	AURA squared 52
Opening at Base	A - 20"	A - 26"	A - 32"	A - 36"
Burner Pan Access	B - 9"	B - 13"	B - 17"	B - 20"
Burner Pan Height	C - 10"	C - 10"	C - 10"	C - 10"
Length	D - 36"	D - 42"	D - 48"	D - 52"
Burner Options	E - - -	E - - -	E - - -	E - - -
Stainless Steel Burner	88,000 BTU	95,000 BTU	150,000 BTU	150,000 BTU
Warming Trands Burner	120,000 BTU	140,000 BTU*	180,000 BTU*	180,000 BTU
Crated Dimensions	39"x39"x23"	45"x45"x23"	51"x51"x23"	56"x56"x23"
Shipping Weight	- 515 LBs	- 655 LBs	- 820 LBs	- 930 LBs
Shell Weight	- 250 LBS	- 300 LBs	- 360 LBs	- 405 LBs

! WARNINGS !

FOR OUTDOOR USE ONLY

POTENTIAL CARBON MONOXIDE HAZARD

Do not store or use flammable liquids in the vicinity of this product

To be installed by licensed plumber or contractor

TYPICAL CLEARANCES

36" of clearance from the side elevations of the fire table

80" of clearance from the top surface of the fire table

NATURAL GAS SUPPLY

Ensure that the service supplying the fire feature is fitted with a positioned shut off valve that is easily accessible

SUPPLY PRESSURE

Minimum - 3.5" WC

Normal - 7.0" WC

Maximum - 14.0" WC (1/2psi)

- - -

Check with local inspector if any further specifications are required for permitted installations



LUMACAST

3261 National Ave
San Diego, CA 92113
t: +1 888 710 1026
www.lumacast.com

PROJECT INFORMATION

PROJECT:
LUMACAST FIRE TABLE
AURA squared

DESIGNER:
LUMACAST

DRAWING INFORMATION

DRAWING PACKAGE:
2D SHOP DRAWINGS
SHEET CONTENTS:
SPECIFICATIONS

MORE INFORMATION



SCAN TO LEARN MORE

AUTHOR AUTHOR
EGI 10/23

AU2

.2

SHEET NO

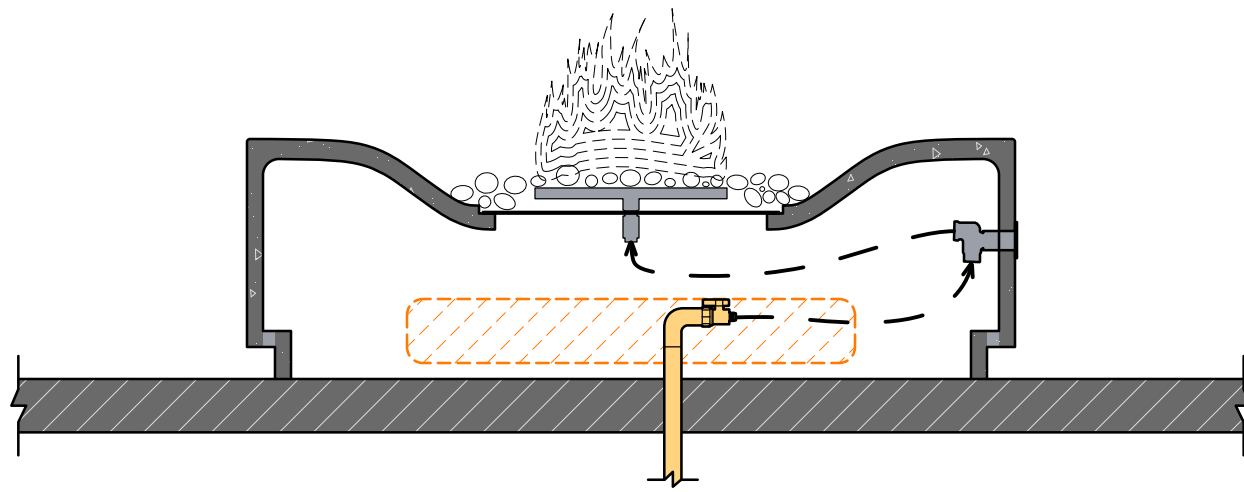

AU2.3.1 SIDE SECTION
SCALE: 1" = 1' - 0"

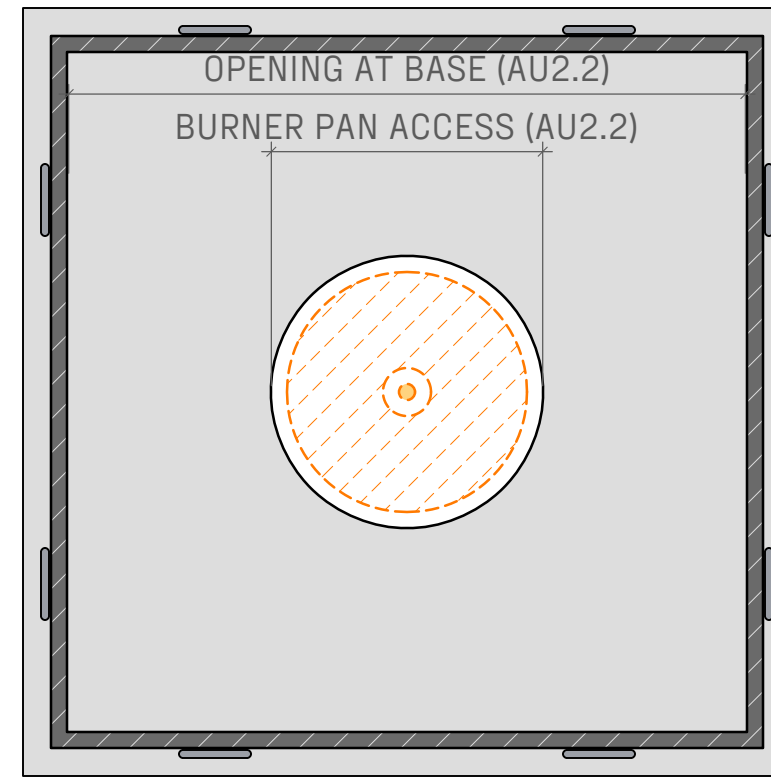

AU2.3.2 PLAN VIEW
SCALE: 1" = 1' - 0"

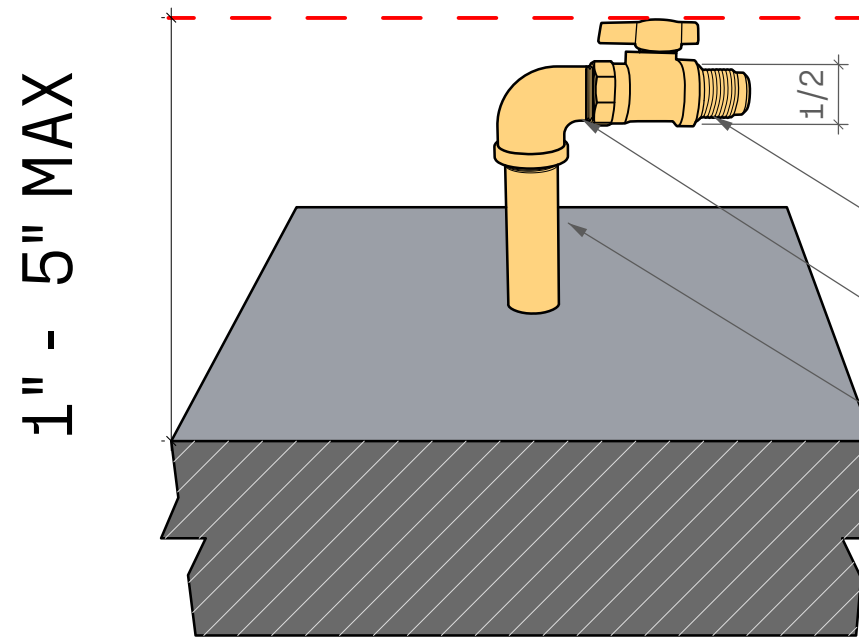

AU2.3.3 PERSPECTIVE
SCALE: n/a

- BRASS FNPT X FLARE GAS BALL VALVE: 1/2" STREET ELBOW
- GALVANIZED NIPPLE 3/4" - 1" DEPENDING ON BTU SEE PLUMBER

PLUMBING HARD LINE

For successful installation, hardline stub up should be capped off between 1" and 5" off finished floor.

Lumacast White Glove Delivery and Installation can only be done on IPS Piping



LUMACAST

3261 National Ave
San Diego, CA 92113
t: +1 888 710 1026
www.lumacast.com

PROJECT INFORMATION

PROJECT:
LUMACAST FIRE TABLE
AURA squared

DESIGNER:
LUMACAST

DRAWING INFORMATION

DRAWING PACKAGE:
2D SHOP DRAWINGS
SHEET CONTENTS:
HARDLINE DIAGRAM

MORE INFORMATION



SCAN TO LEARN MORE

AUTHOR	AUTHOR
EGI	10/23

AU2

.3

SHEET NO